

BALDOR® • RELIANCE

Product Information Packet

ELECTRIC MOTOR WHOLESAL.COM

GS1518G

S-918-15-G

Nameplate NP1753L				
INPUT H.P.	.976			
RATIO	15	R TORQ-INLB	448	
	S-918-15-G			
CAT./SPEC	GS1518G		GR0089C004	
DATE CODE				

Parts List		
Part Number	Description	Quantity
HG0015A16	918 WMGR HSG-SYMM, SEALED	1.000 EA
133-18	1/4 NPTF-HX SOC PIPE PLG 3/4 TAPER	1.000 EA
HW5000A94	N5000-206 RETAINER RING	2.000 EA
918-615	918 EXT WORM 15:1 RATIO	1.000 EA
BG6304A01	6304 OPEN,C3,SLUSH	1.000 EA
918-11-10	I/P BRG SHIM (.010" THICK)	1.000 EA
918-11-3	I/P BRG SHIM (.003" THICK)	3.000 EA
HA3555A04	EXPANSION PLUG 2.053/2.049 X 9/32	1.000 EA
BG6304A01	6304 OPEN,C3,SLUSH	1.000 EA
HW4600D05	SEAL .625 X 1.375 X .250 SGL LIP, CR #63	1.000 EA
918-3	918 STD INPUT BRG SUPP	1.000 EA
10XN3118K14	5/16-18 X .88 HEX MACH SCREW, GRADE 5	4.000 EA
HW1001A31	LOCKWASHER 5/16, ZINC PLT.591 OD, .319 I	4.000 EA
BS0014A02	918-5 BEARING SUPPORT, OPEN-FOR SYMM HSG	1.000 EA
GS0034A01	WORMGEAR GASKET, .003 (GREEN), 3.15 ID X	1.000 EA
GS0034A02	WORMGEAR GASKET, .005 (BLUE), 3.15 ID X	2.000 EA
GS0034A03	WORMGEAR GASKET, .010 (BROWN), 3.15 ID X	2.000 EA
HW4600C86	0.875 X 1.375 X 0.250 DBLLIP	1.000 EA
10XN3118K14	5/16-18 X .88 HEX MACH SCREW, GRADE 5	4.000 EA
SG0016B09	918 GEAR SHAFT ASSY 15:1, SGL O/P, W/COM	1.000 EA
BS0046A02	918 BEARING SUPPORT MACH. CLOSED	1.000 EA
GS0034A01	WORMGEAR GASKET, .003 (GREEN), 3.15 ID X	1.000 EA
GS0034A02	WORMGEAR GASKET, .005 (BLUE), 3.15 ID X	2.000 EA
GS0034A03	WORMGEAR GASKET, .010 (BROWN), 3.15 ID X	2.000 EA

Parts List (continued)		
Part Number	Description	Quantity
10XN3118K14	5/16-18 X .88 HEX MACH SCREW, GRADE 5	4.000 EA
HA3557A01	ALLIANCE #I-5/16 MTG HOLE PLUG (YELLOW)	4.000 EA
MJ1000A90	KLUBERSYNTH UH1-6-460 WORMGEAR OIL	0.125 GA
MJ5019A01	ADHESIVE LOCTITE #680 WAS BAD4525	0.001 EA
MJ5004A35	ADHESIVE LOCTITE #243-31 50 ML	0.001 EA
MJ5001A19	LOCTITE #598 ULTRA BLACK, 50 LB PAIL, IT	0.010 LB
MG1000G28SPP	400-0096 Haps Free Met. Gray Lacq.	0.010 GA
LB5042	TOE TAG, OIL PREFILL KLUBERSYN (250/pk)	1.000 EA
LT0066A08	REDUCER INSTALL/MAINT - KLUBE 11/05	1.000 EA
NP1753L	RIVETED LASER NP, GEAR REDUCER, UH1 6-46	1.000 EA
LB1242	ADHESIVE PATCH 1.10 X 2.03 X .045 THICK	1.000 EA
35PA1000	PACKING GROUP	1.000 EA
HW2513A03	KEY .188 X 1.000 1018 STEEL	1.000 EA
HW2513A05	KEY .188 X 1.250 1018 STEEL	1.000 EA
MP1009A01	4 X 4 ZIP POLYBAG, 4 MIL	1.000 EA

Accessories		
Part Number	Description	Multiplier
B18H71	BASE-HORIZONTAL POS. A/B 918	A8
B18V81	BASE-VERTICAL LOW POS. D/F 915/918	A8
B18V91	BASE-VERTICAL HIGH POS. C/E 915/918	A8
B18J92	BASE-INPUT VERTICAL POS. X/Y 915/918	A8
FL18HK	OUTPUT FLANGE KIT, STAMP STEEL 918	A8
SFL918B5	NEMA C-FLG.KIT,COUPLING TYPE	A8
RBK18B5	RISER BLOCK KIT 56C/140TC 918	A8

GY0089A01

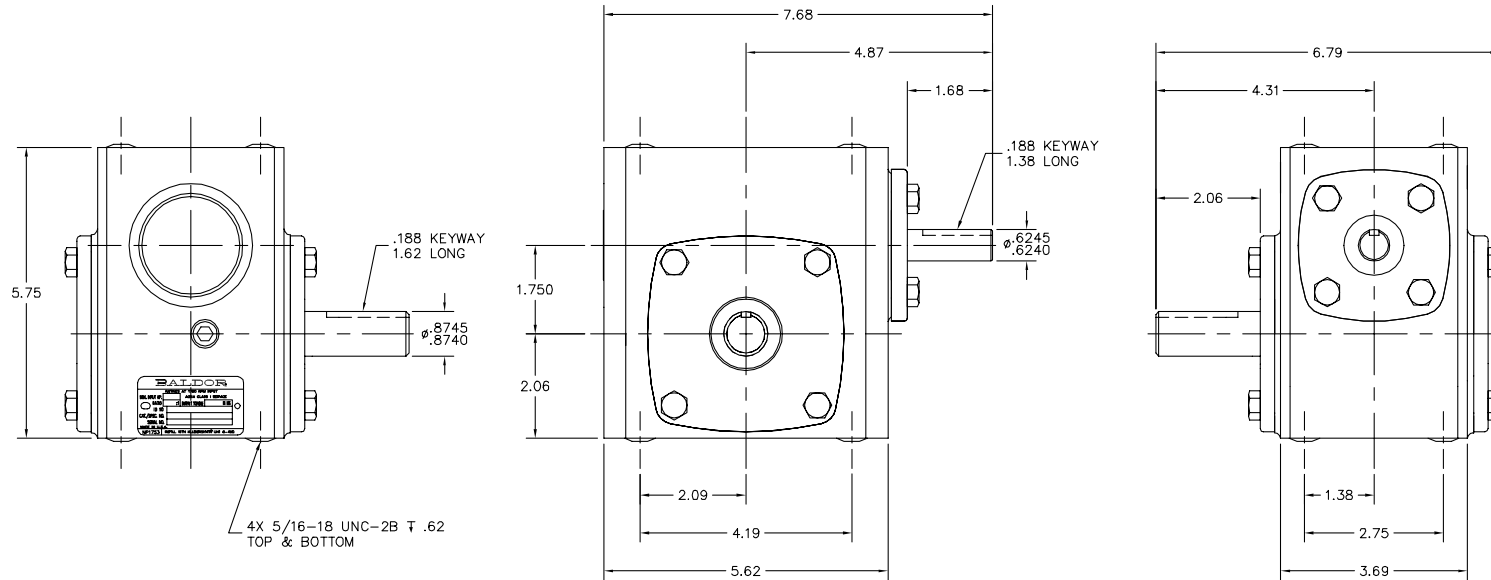

GY0089A01

REV. DESC: ADD SECTION VIEW		
REV. LTR: B	VERSION: 02	TDR: 000000435804
FILE: \CKA\00009\673	REVISED: 07:59:25 06/27/2007	BY: CKPHIWO
MTL: -		

Baldor • Dodge • Reliance

S-918-G STANDARD MOUNTING

GY0089A01

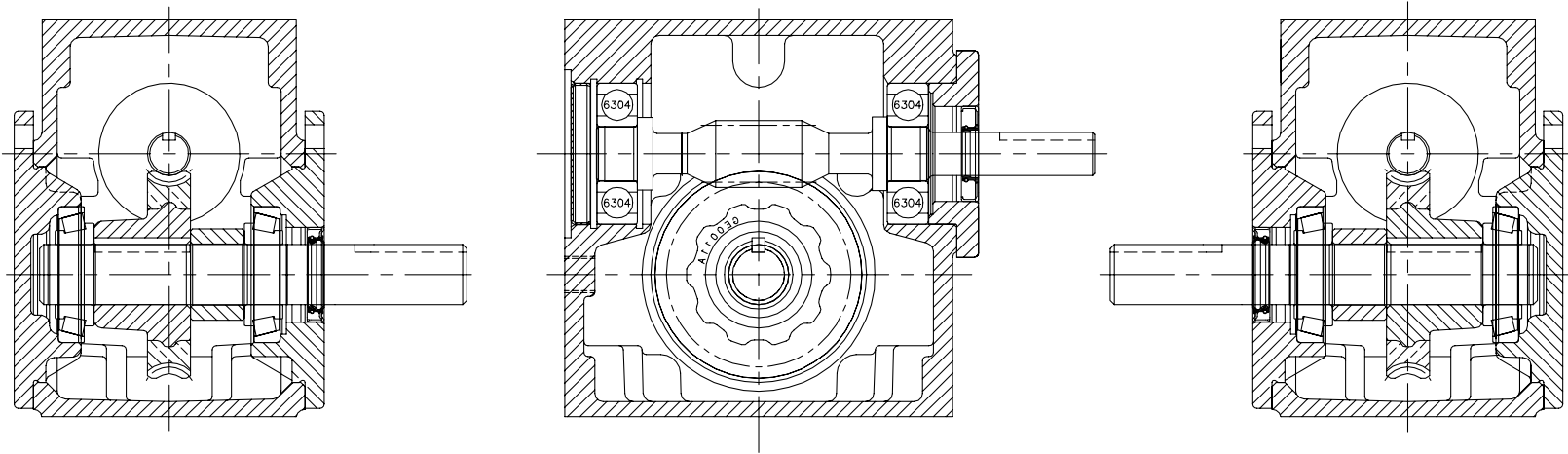

REV. DESC: ADD SECTION VIEW		
REV. LTR: B	VERSION: 02	TDR: 000000435804
FILE: \CKA\00009\673	REVISED: 07:59:26 06/27/2007	BY: CKPHIWO
MTL: -		

Baldor • Dodge • Reliance

S-918-G STANDARD MOUNTING

GY0089A01

P. O. BOX 2400 • FORT SMITH, ARKANSAS 72902-2400 U.S.A. • (479) 646-4711 • FAX (479) 648-5792



REDUCER INSTALLATION, MAINTENANCE AND LUBRICATION

Baldor reducers achieve maximum performance and life when installed properly. Please follow these instructions carefully.

INSTALLATION

Baldor reducers filled with Kluber Klubersynth UH1-6-460 synthetic lubricant are ready for immediate use. These reducers are completely sealed and require no breather vents. The design and synthetic lubrication allow efficient operation to reduce operating temperature and minimize internal pressure build up. The reducer has been filled with the correct amount of oil for all approved mounting positions. Do not add or remove any oil during installation or after the break-in period.

Mount the reducer on a flat surface, to assure proper bolt tension and prevent damage to the mounting base. When direct coupling the reducer to the driven machine, carefully align the reducer output shaft to the input shaft of the driven machine. These shafts must be connected with a flexible coupling.

Power transmission components, such as sprockets, gears, or sheaves, mounted on the reducer shafts produce overhung loads. Mount these components as close as possible to the reducer with the hub facing outward. This mounting minimizes the load on the reducer shaft and bearings for increased life. Carefully align these components with their counterparts on the driven machine.

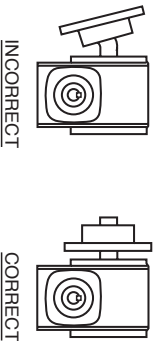

MAINTENANCE

Baldor reducers require no periodic maintenance. Visual inspection (for oil leakage and general operating condition) and a simple cleaning to remove dirt build up is recommended.

Accumulation of material on the reducer can lead to overheating and reduced life.

LUBRICATION

Klubersynth UH1-6-460 is suitable for USDA Class H1 environments. This synthetic lubrication does not require periodic changing. The lubrication should only be replaced when maintenance is performed that requires disassembly. Use only Klubersynth UH1-6-460. This lubrication is suitable for a wide temperature range (-13° to 320° F). However, refer to “Operating Environment” section for the ambient operating temperature for Baldor speed reducers.

MOUNTING POSITIONS

Because Baldor speed reducers do not require a breather vent, they are suitable for mounting in a wide variety of mounting positions without modification.

Avoiding those positions where the high-speed (input) oil seal is immersed in oil, will provide greater security against high-speed (input) seal wear. For maximum seal life, the reducer should be mounted with the high-speed (input) shaft as high as possible above the low-speed (output) shaft. Since the high-speed (input) oil seal experiences more revolutions than the output, it will also experience more heat and more wear. When the speed reducer is mounted in a manner where the high-speed (input) seal is below the oil level, and the seal is nearing the end of its useful life, the steady head of oil on the seal will result in a leak. If the reducer is mounted with the high-speed (input) seal above the oil level it may not leak even when the seal has reached the end of its useful life.

OPERATING ENVIRONMENT

Baldor Reducers are designed to operate in ambient temperatures of -10°F to 100°F. The oil sump temperature of the reducer must not exceed 200°F. Consult the factory for applications requiring ambient operating temperature outside this range.

The input horsepower rating shown on the nameplate of each Baldor speed reducer is the continuous mechanical rating of 1.0 service factor at 1750 RPM. Before placing the reducer into service, confirm that its horsepower rating is consistent with the motor horsepower and desired service factor. Service factor and speed reducer ratings can be found in your Baldor Gear Product brochure, BR1600.

“C” FLANGE – HOLLOW BORE WORM STYLE:

- STEP 1.** Position key in reducer worm bore.
- STEP 2.** Apply anti-seize compound to the motor shaft.
- STEP 3.** Line up the key with the key slot and slip the motor shaft in the reducer worm bore.

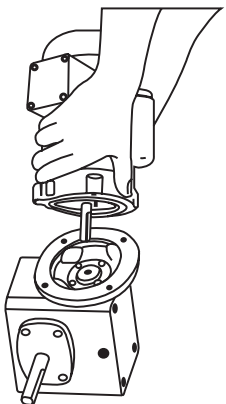

- STEP 4.** Install the four supplied bolts and lock washers and tighten bolts evenly for a solid fit between motor and “C” flange.

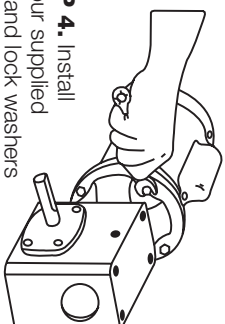

EXTENDED “C” FLANGE WITH FLEXIBLE COUPLING STYLE:

- STEP 1.** Mount one coupling half on motor shaft so that the coupling half and end of key are flush with end of motor shaft. (See Drawing A).
- STEP 2.** Tighten coupling setscrews. (Thread locking compound is recommended on all coupling setscrews.)
- STEP 3.** Measure the distance from inner face of coupling to motor mounting surface. (See Drawing A “L”).
- STEP 4.** Mount other coupling half on the reducer input shaft so the coupling end measures the same distance “L” to the mounting surface of the “C” flange. (See Drawing B “L”)
- STEP 5.** Tighten setscrews.

Follow the lubrication directions.

