



**BALDOR® • RELIANCE **

**Product Information Packet**

**ELECTRIC MOTOR WHOLESAL.COM**

**WDGF3032BG**

**WDF-932-30-B7-G**

Nameplate NP1756				
INPUT H.P.	2.81			
RATIO	30	R TORQ-INLB	2462	
	WDF-932-30-B7-G			
CAT./SPEC	WDFG3032BG			GR0211C005
DATE CODE				

Parts List		
Part Number	Description	Quantity
HG0019A10	932 WMGR HSG-SYMM, SEALED W/NP HOLES	1.000 EA
HA4027A03	SQUARE HEAD PIPE PLUG 1/2" NPTF #304 S.S	1.000 EA
926-1SR	N5000-281 WALDES TRUARC RETAINING RING	1.000 EA
WM0064B23	932 MTZ WORM ASSY 30:1 RATIO 7/8 BORE	1.000 EA
BG5306A01	5306 OPEN,D.ROW,ANG.CONTACT,SLUSH	1.000 EA
HW5060A38	RET RING 5160-118(WALDES)	1.000 EA
BS0034A01	926-3 BEARING SUPPORT, OPEN	1.000 EA
HW4600D07	1.000 X 1.499 X 0.250 SGLLIP, CR #9876	1.000 EA
10XN3118S12	5/16-18 X 3/4 HEX HEAD CAP, STAINLESS ST	4.000 EA
HW4600F16	1.688 X 2.835 X 0.469 SGLLIP, HNBR	1.000 EA
GF0007A01	926-3F56 GEAR FLANGE MACH 2.62 & 3.25 CD	1.000 EA
84XN3118S24	5/16-18X1 1/2 HX SOC HD CAP SCREW, STAIN	4.000 EA
HW1001S31	WASHER, 5/16 SPLT LK, STAINLESS STEEL	4.000 EA
BS0023A03	932-5 BG SPT ASSY, OPEN - FOR SYMM H	1.000 EA
GS0038A01	WORMGEAR GASKET, .003 (GREEN), 5.72 ID X	1.000 EA
GS0038A02	WORMGEAR GASKET, .005 (BLUE), 5.72 ID X	2.000 EA
GS0038A03	WORMGEAR GASKET, .010 (BROWN), 5.72 ID X	2.000 EA
HW4600C89	1.375 X 2.125 X 0.311 DBLLIP	1.000 EA
HW4600C51	31X39X7.5MM FACE SEAL FOR 1.375 DIA. SH	1.000 EA
10XN3118S12	5/16-18 X 3/4 HEX HEAD CAP, STAINLESS ST	6.000 EA
SG0015B25	932 COMP GEAR SHAFT ASSY 30:1, SGL O/P,	1.000 EA
BS0051A02	932 OPT BG SPT ASSY, CLOSED - FOR	1.000 EA
GS0038A01	WORMGEAR GASKET, .003 (GREEN), 5.72 ID X	1.000 EA
GS0038A02	WORMGEAR GASKET, .005 (BLUE), 5.72 ID X	2.000 EA

Parts List (continued)		
Part Number	Description	Quantity
GS0038A03	WORMGEAR GASKET, .010 (BROWN), 5.72 ID X	2.000 EA
10XN3118S12	5/16-18 X 3/4 HEX HEAD CAP, STAINLESS ST	6.000 EA
FN0084A00	FAN, MOLDED PLASTIC 932-400, 4.63 OD	1.000 EA
84XN1032S12	SCREW SOCKET HD #10-32 X 3/4 S.S.	1.000 EA
XY1032S02	10-32 HEX NUT R.H. S STL	1.000 EA
HW1004S10	WASHER, #10 INTERNAL TOOTH SS	1.000 EA
FH0016A00	FAN COVER, 932, SABIC XENOY X5410	1.000 EA
12XN1032S08	10-32X1/2 HEX HD SLTD STAINLESS STEEL	4.000 EA
HA3557A03	I-7/16 SHORT STYLE PLUG (YELLOW)	4.000 EA
MJ1000A90	KLUBERSYNTH UH1-6-460 WORMGEAR OIL	0.625 GA
MJ5019A01	ADHESIVE LOCTITE #680 WAS BAD4525	0.001 EA
MJ5004A35	ADHESIVE LOCTITE #243-31 50 ML	0.001 EA
MJ5001A19	LOCTITE #598 ULTRA BLACK, 50 LB PAIL, IT	0.010 LB
MG1500Y11	707.11A & 707.11B WILKOFASST YELLOW EPOXY	0.010 GA
MG1025W11	PAINT- 781-101 WILKOFASST WHITE EPOXY	0.010 GA
LB5042	TOE TAG, OIL PREFILL KLUBERSYN (250/pk)	1.000 EA
LT0066A08	REDUCER INSTALL/MAINT - KLUBE 11/05	1.000 EA
LB1242	ADHESIVE PATCH 1.10 X 2.03 X .045 THICK	1.000 EA
NP1756	NAMEPLATE, GEAR REDUCER, KLUBERSYNTH UH1	1.000 EA
85XU0208S03	2 X 3/16 DRIVE PIN S.S. (BMH5033)	2.000 EA
G1PA1002	PKG GROUP, LG GEAR, W/G1PK5002A01	1.000 EA
HW2502F22	KEY, 5/16 SQ X 2.500 SS AUTOMATED	1.000 EA
10XN3816S16	3/8-16 X 1 HEX HD CAP SCREW, STAINLE	4.000 EA
HW1001S38	WASHER, 3/8 SPLT LK, STAINLESS STEEL	4.000 EA

Parts List (continued)		
Part Number	Description	Quantity
MJ1000B01	ANTISEIZE - ALTEMP Q NB 50, 750 GRAM CAN	0.001 EA
MP1009A01	4 X 4 ZIP POLYBAG, 4 MIL	1.000 EA

<b>Accessories</b>		
<b>Part Number</b>	<b>Description</b>	<b>Multiplier</b>
WDB32H71	WASHDOWN BASE-HORIZONTAL POS. A/B 932	A8
133-6FBA	INPUT BUSHING KIT 5/8 TO 7/8	A8

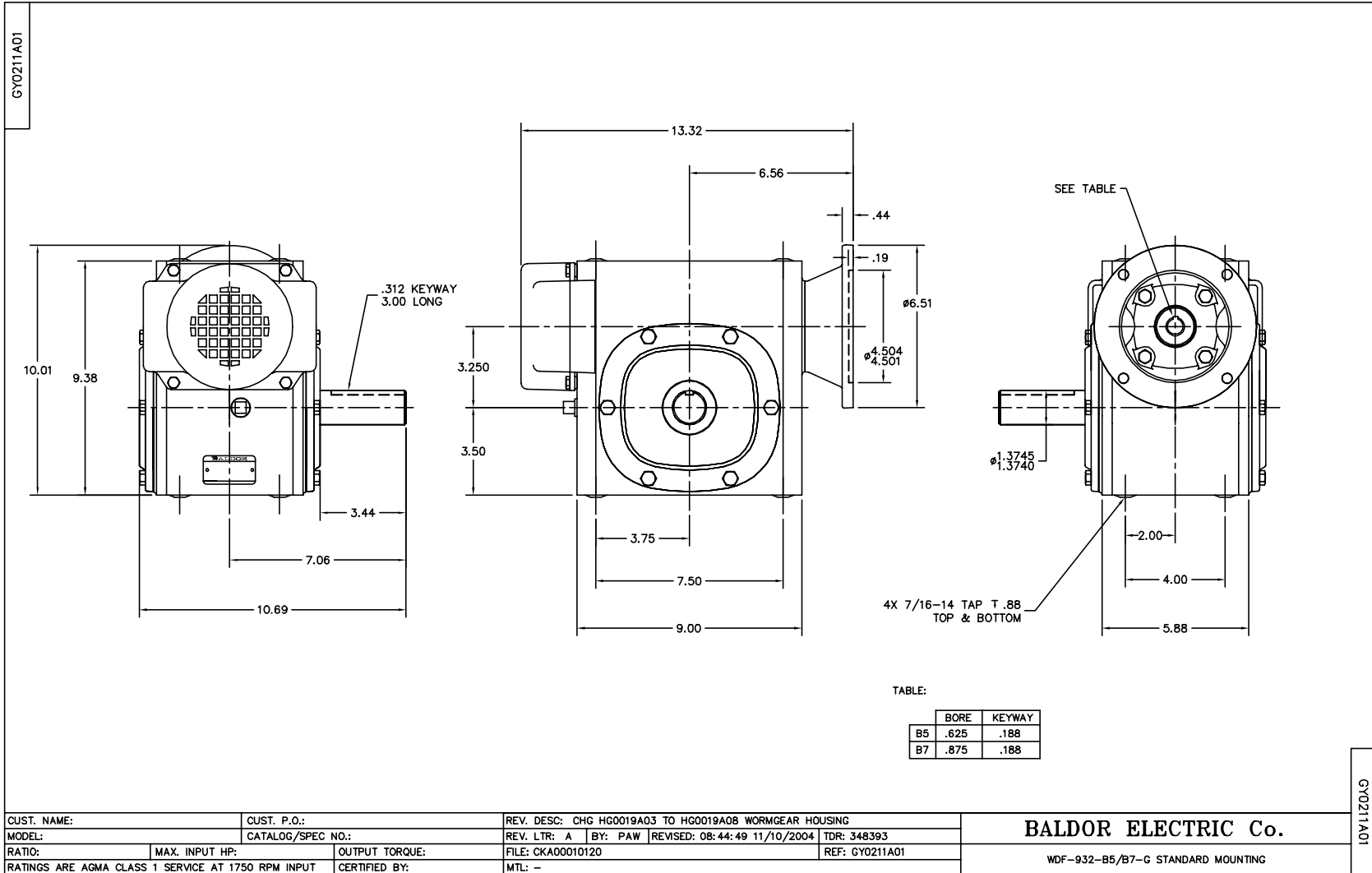

P. O. BOX 2400 • FORT SMITH, ARKANSAS 72902-2400 U.S.A. • (479) 646-4711 • FAX (479) 648-5792



## REDUCER INSTALLATION, MAINTENANCE AND LUBRICATION

Baldor reducers achieve maximum performance and life when installed properly. Please follow these instructions carefully.

### INSTALLATION

Baldor reducers filled with Kluber Klubersynth UH1-6-460 synthetic lubricant are ready for immediate use. These reducers are completely sealed and require no breather vents. The design and synthetic lubrication allow efficient operation to reduce operating temperature and minimize internal pressure build up. The reducer has been filled with the correct amount of oil for all approved mounting positions. Do not add or remove any oil during installation or after the break-in period.

Mount the reducer on a flat surface, to assure proper bolt tension and prevent damage to the mounting base. When direct coupling the reducer to the driven machine, carefully align the reducer output shaft to the input shaft of the driven machine. These shafts must be connected with a flexible coupling.

Power transmission components, such as sprockets, gears, or sheaves, mounted on the reducer shafts produce overhung loads. Mount these components as close as possible to the reducer with the hub facing outward. This mounting minimizes the load on the reducer shaft and bearings for increased life. Carefully align these components with their counterparts on the driven machine.

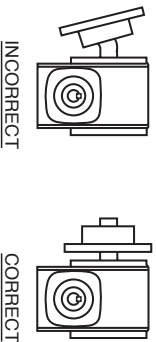

### MAINTENANCE

Baldor reducers require no periodic maintenance. Visual inspection (for oil leakage and general operating condition) and a simple cleaning to remove dirt build up is recommended.

Accumulation of material on the reducer can lead to overheating and reduced life.

### LUBRICATION

Klubersynth UH1-6-460 is suitable for USDA Class H1 environments. This synthetic lubrication does not require periodic changing. The lubrication should only be replaced when maintenance is performed that requires disassembly. Use only Klubersynth UH1-6-460. This lubrication is suitable for a wide temperature range (-13° to 320° F). However, refer to “Operating Environment” section for the ambient operating temperature for Baldor speed reducers.

### MOUNTING POSITIONS

Because Baldor speed reducers do not require a breather vent, they are suitable for mounting in a wide variety of mounting positions without modification.

Avoiding those positions where the high-speed (input) oil seal is immersed in oil, will provide greater security against high-speed (input) seal wear. For maximum seal life, the reducer should be mounted with the high-speed (input) shaft as high as possible above the low-speed (output) shaft. Since the high-speed (input) oil seal experiences more revolutions than the output, it will also experience more heat and more wear. When the speed reducer is mounted in a manner where the high-speed (input) seal is below the oil level, and the seal is nearing the end of its useful life, the steady head of oil on the seal will result in a leak. If the reducer is mounted with the high-speed (input) seal above the oil level it may not leak even when the seal has reached the end of its useful life.

### OPERATING ENVIRONMENT

Baldor Reducers are designed to operate in ambient temperatures of -10°F to 100°F. The oil sump temperature of the reducer must not exceed 200°F. Consult the factory for applications requiring ambient operating temperature outside this range.

The input horsepower rating shown on the nameplate of each Baldor speed reducer is the continuous mechanical rating of 1.0 service factor at 1750 RPM. Before placing the reducer into service, confirm that its horsepower rating is consistent with the motor horsepower and desired service factor. Service factor and speed reducer ratings can be found in your Baldor Gear Product brochure, BR1600.



**“C” FLANGE – HOLLOW BORE WORM STYLE:**

**STEP 1.** Position key in reducer worm bore.  
**STEP 2.** Apply anti-seize compound to the motor shaft.  
**STEP 3.** Line up the key with the key slot and slip the motor shaft in the reducer worm bore.

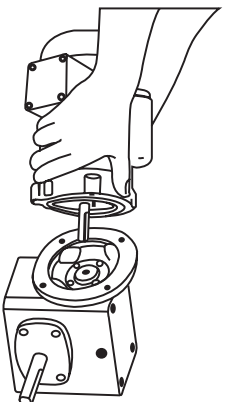

**STEP 4.** Install the four supplied bolts and lock washers and tighten bolts evenly for a solid fit between motor and “C” flange.

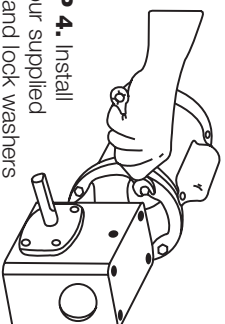

**EXTENDED “C” FLANGE WITH FLEXIBLE COUPLING STYLE:**

- STEP 1.** Mount one coupling half on motor shaft so that the coupling half and end of key are flush with end of motor shaft. (See Drawing A).
- STEP 2.** Tighten coupling setscrews. (Thread locking compound is recommended on all coupling setscrews.)
- STEP 3.** Measure the distance from inner face of coupling to motor mounting surface. (See Drawing A “L”).
- STEP 4.** Mount other coupling half on the reducer input shaft so the coupling end measures the same distance “L” to the mounting surface of the “C” flange. (See Drawing B “L”)
- STEP 5.** Tighten setscrews.

Follow the lubrication directions.

