

BALDOR® • RELIANCE

Product Information Packet

ELECTRIC MOTOR WHOLESAL.COM

D5530R

30 1750/2300 LC2812ATZ TEFC 500V

Part Detail			
Type:	DC	Prod. Type:	TR
Power Code:	C	Weight:	895
Frame Group:	LC 2812ATZ	Mounting Pos.:	F1
HP:	30	Enclosure:	TEFC
RPM:	1750/2300	Wound:	STAB SHUNT
Service Factor:	1.0	Arm V:	500
Arm A:	50.00	Field V:	300
Field A:	1.74	Field A Hot:	1.21/.90
Insulation Class:	F	Ambient:	40
Duty:	CONT	DE Bearing:	65BC03J30X
ODE Bearing:	55BC02J30X	Brushes:	419904-51AD
Brush Qty.:			

406770-002

**CONNECTION DIAGRAM
D-C MOTOR - STAB. SHUNT
DUAL VOLTAGE FIELD**

406770-002

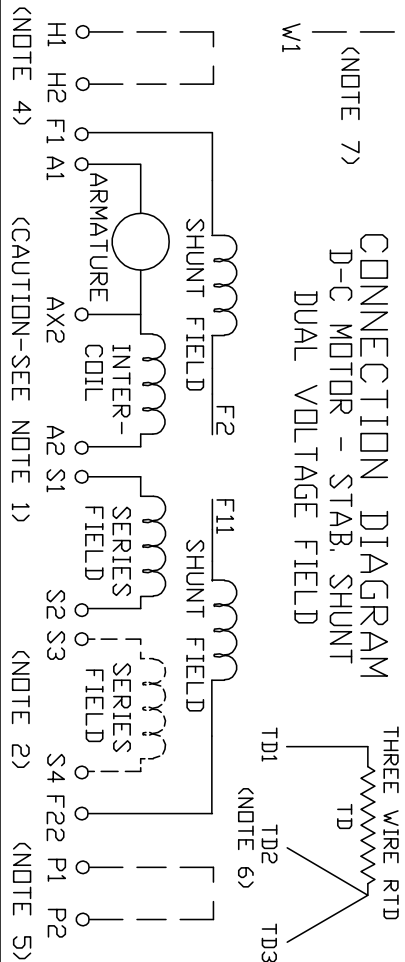

ARMATURE AND FIELD EXTERNAL CONNECTIONS

WARNING- SEE NOTE 8 FOR GROUNDING INSTRUCTIONS

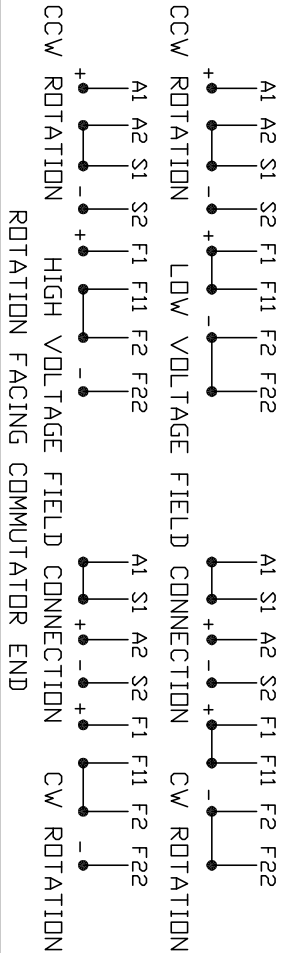

1. **CAUTION** - ARMATURE AND SERIES FIELD MAY HAVE MULTIPLE LEADS. CONNECT ALL LUGS WITH THE SAME MARKING TOGETHER.
 2. OPTIONAL SERIES FIELD IS MARKED S3 AND S4. FOR CUMULATIVE SERIES FIELD, CONNECT S3 TO S2 AND CONNECT S4 TO NEGATIVE. FOR DIFFERENTIAL SERIES FIELD CONNECT S4 TO S2 AND S3 TO NEGATIVE.
 3. OPTIONAL CONTROL SIGNAL LEAD IS MARKED AX2. ALWAYS TAKE INTERPOLE DROP BETWEEN A2 AND AX2. NOTE: NEMA DESIGNATION FOR AX2 IS LETTER C.
 4. SPACE HEATERS, WHEN PROVIDED, WILL HAVE LEADS MARKED H1 AND H2, H3, H4, ETC.
 5. THERMAL PROTECTOR, WHEN PROVIDED, WILL HAVE LEADS MARKED P1 AND P2, P3, P4, ETC.
 6. WINDING RTD'S, WHEN PROVIDED, WILL HAVE LEADS MARKED TD1, TD2, & TD3.
 7. BRUSH WEAR SENSOR, WHEN PROVIDED, WILL HAVE LEAD MARKED W1.
 8. **WARNING** - MOTOR MUST BE GROUNDED TO PREVENT SERIOUS INJURIES TO PERSONNEL. GROUND THE MOTOR PER IEC, NATIONAL ELECTRICAL CODE AND ANY APPLICABLE LOCAL ELECTRICAL CODES. A TAPPED HOLE IS PROVIDED IN THE CONDUIT BOX ON THE FOOT. FRAME BRACE OR OPPOSITE OPPOSITE DRIVE END BRACKET, ADJACENT TO THE TERMINAL BOX FOR FOR MOTOR GROUNDING. GROUND LEAD, WHEN PROVIDED, WILL BE GREEN.
- CUSTOMER _____ ORDER NO. _____ S.D. NO. _____
 CUSTOMER _____ RELIANCE

REV. DESC: UPDATE LOGO AND TITLEBLOCK: LOADED TO BUS		
REV. LTR: -	VERSION: 00	TDR: 000000781086
FILE: \RSN\00026\434	REVISED: 02: 35: 07 02/01/2013	
MTL: -	BY: MGHP	



D-C MOTOR CONNECTION DIAGRAM STAB. SHUNT, DUAL VOLTAGE FIELD

SH 1 of 1