

PRODUCT INFORMATION PACKET



Model No: C42C17FB2C

Catalog No: 092114.00

1/8HP..1725RPM.42.TEFC.115/208-230V.1PH.60HZ.CONT.NOT.40C.1.15SF.RIGID.GENERAL
PURPOSE.C42C17FB2C

Totally Enclosed Fan Cooled (TEFC)



Regal and Leeson are trademarks of Regal Beloit Corporation or one of its affiliated companies.

©2018 Regal Beloit Corporation, All Rights Reserved. MC017097E





Nameplate Specifications

Output HP	0.13 Hp	Output KW	0.09 kW
Frequency	60 Hz	Voltage	115/208-230 V
Current	3.2/1.6 A	Speed	1725 rpm
Service Factor	1.15	Phase	1
Efficiency	48 %	Duty	Continuous
Insulation Class	B	Design Code	L
KVA Code	M	Frame	42
Enclosure	Totally Enclosed Fan Cooled	Overload Protector	No
Ambient Temperature	40 °C	Drive End Bearing Size	6203
Opp Drive End Bearing Size	6203	UL	Recognized
CSA	Y	CE	N
IP Code	43		

Technical Specifications

Electrical Type	Capacitor Start Induction Run	Starting Method	Across The Line
Poles	4	Rotation	Selective Counterclockwise
Mounting	Rigid base	Motor Orientation	HORIZONTAL
Drive End Bearing	BALL	Opp Drive End Bearing	BALL
Frame Material	Rolled Steel	Shaft Type	NEMA 48
Overall Length	9.44 in	Frame Length	6.00 in
Shaft Diameter	0.375 in	Shaft Extension	1.12 in
Assembly/Box Mounting	F1 ONLY		
Outline Drawing	027616-N42	Connection Diagram	005312.01

027616

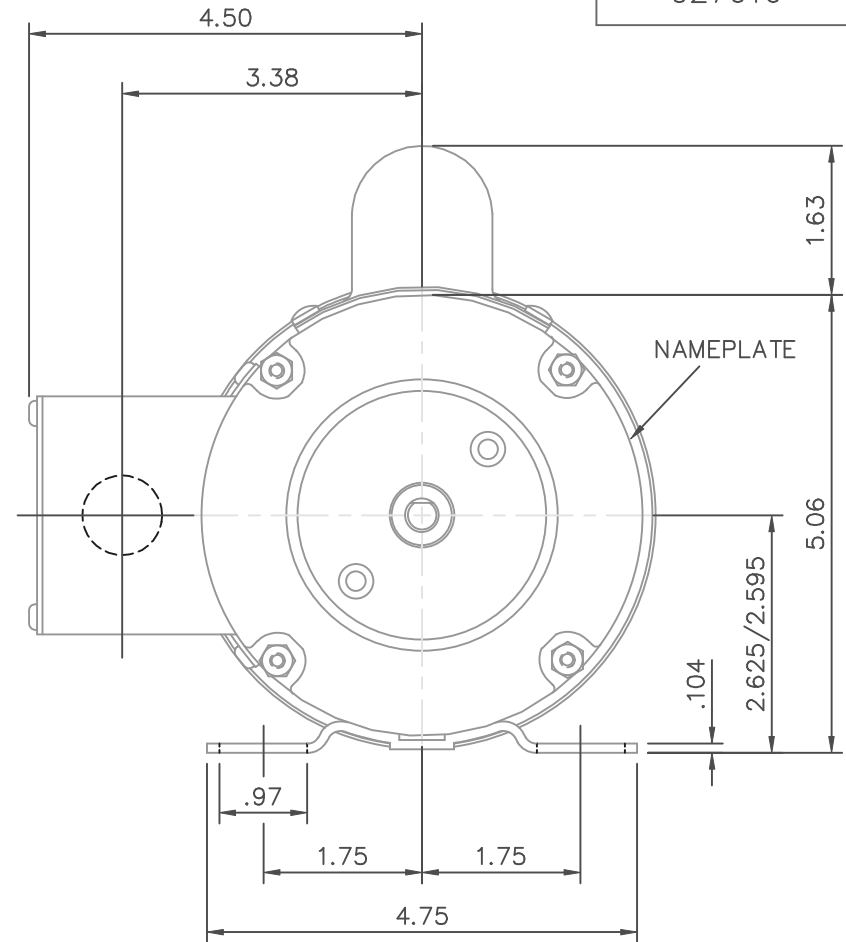
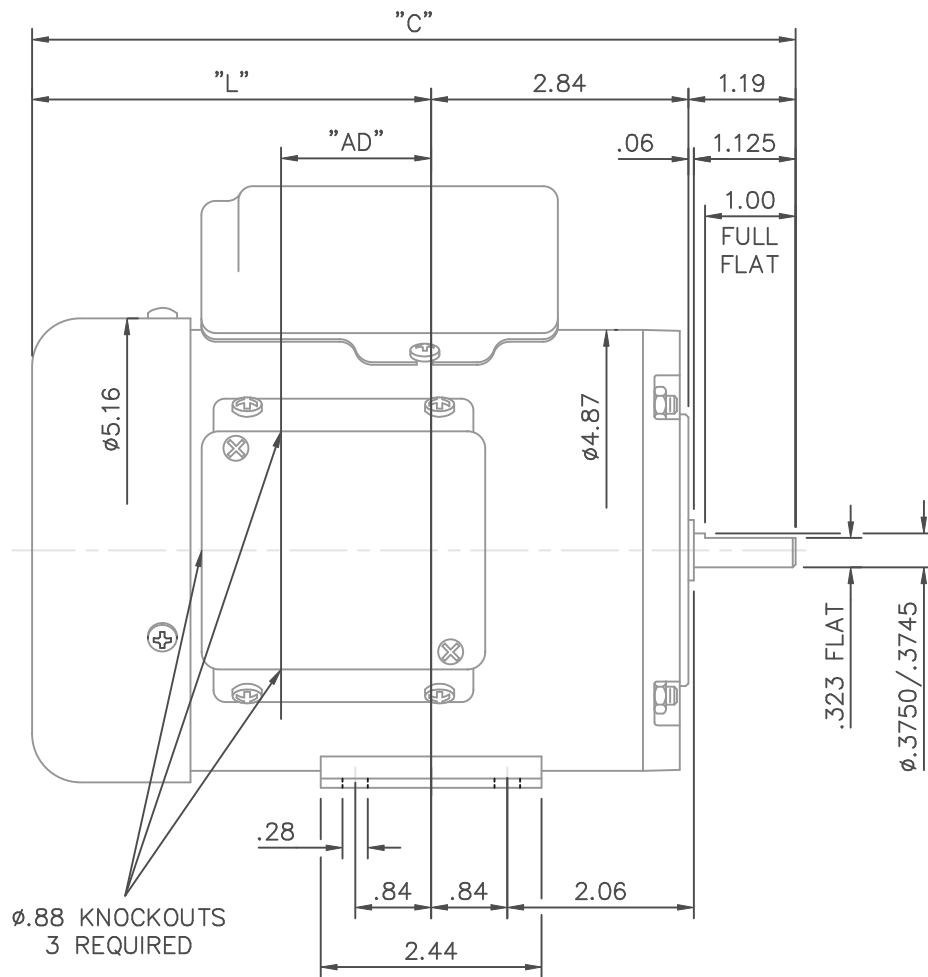

FRAME	"C"	"L"	"AD"	FRAME	"C"	"L"	"AD"
G42	7.94	3.91	1.16	R42	9.94	5.91	3.16
J42	8.44	4.41	1.66	U42	10.44	6.41	3.66
L42	8.94	4.91	2.16	V42	10.94	6.91	4.16
N42	9.44	5.41	2.66	W42	11.44	7.41	4.66

GASKETS THROUGHOUT

TOLERANCES UNLESS OTHERWISE SPECIFIED

DECIMALS

.00	± .01
.000	± .005
.0000	± .0005

FRACTIONS ± 1/64

ANGLES ± 1/2°

INCH/MM

LEESON ELECTRIC CORPORATION

DRAWN PG 3/2/95

CH'K'D.

APPR.

SCALE HALF

REF. 027516

FMF 092111

TITLE OUTLINE - 42 FRAME
TEFC - RIGID MOUNT

MAT'L.

FINISH

STANDARD

SIZE

A

DRAWING NO.

027616

THIS DRAWING IN DESIGN AND DETAIL IS OUR PROPERTY AND MUST NOT BE USED EXCEPT IN CONNECTION WITH OUR WORK ALL RIGHTS OF DESIGN AND INVENTION ARE RESERVED

NO.	REVISION	BY	DATE

VIEW FROM OUTSIDE OF MOTOR AT SWITCH END.

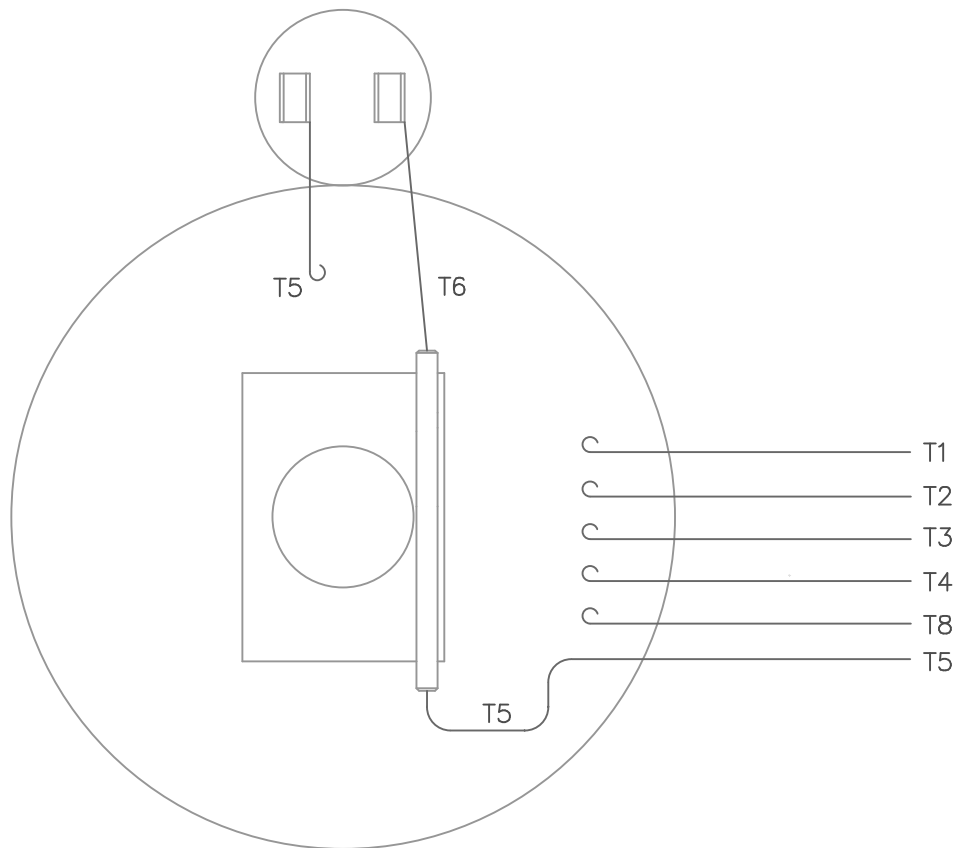

ALL CONNECTIONS ON STATIONARY SWITCH ARE SOLDERED

GEARMOTORS
2-STAGE REF. DECAL 004012
3-STAGE REF. DECAL 081062

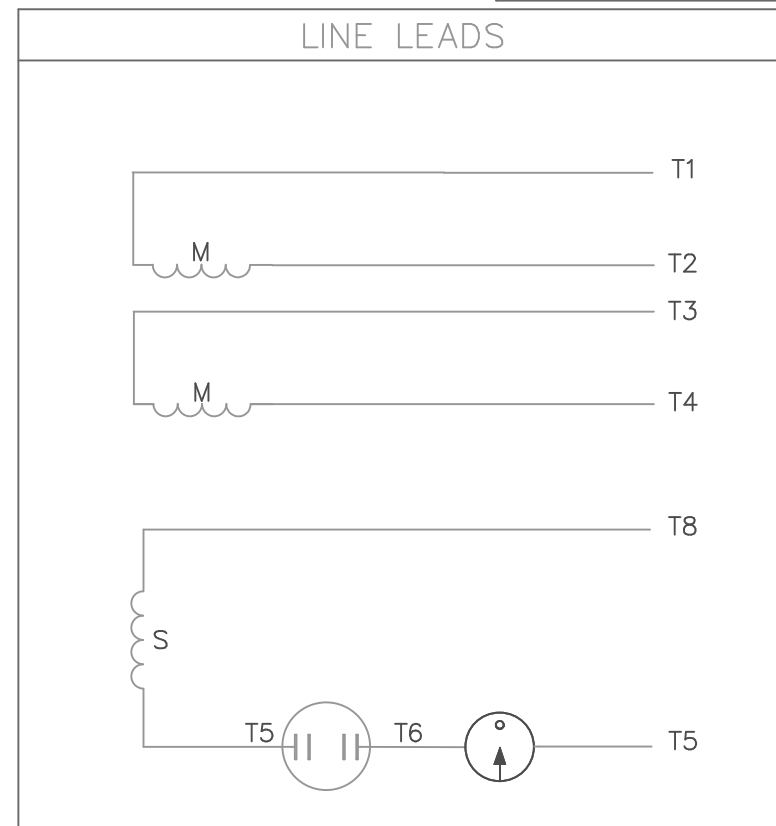

	ROTATION FACING LEAD END	L1	L2	JOIN
HIGH VOLT	C.C.W.	T1	T4 T5	T2, T3 T8
	C.W.	T1	T4 T8	T2, T3 T5
LOW VOLT	C.C.W.	T1, T3 T8	T2, T4 T5	---
	C.W.	T1, T3 T5	T2, T4 T8	---

NO.	REVISION	BY	DATE	FRACTIONS	±
06	ADDED GEARMOTOR NOTE	KMM	04/04/02	TOLERANCES UNLESS OTHERWISE SPECIFIED	
05	UPDATED TO CURRENT STANDARDS	MDN	2/16/00		
04	ADDED PAGE 6	PG	4/5/94	DECIMALS	
03	ADDED PAGE 4 AND 5	MJS	4/7/93	.00	± .01
02	CHANGED TO SOLDERED LEADS	KAZ	7/2/92	.000	± .005
01	ADDED PAGE 2 AND 3	DLL	8/23/90	.0000	± .0005
				ANGLES	± 1/2°
				INCH/MM	

LEESON ELECTRIC CORPORATION			
DRAWN	GS 8/14/89	TITLE	EXT. WIRING DIAGRAM
CH'K'D.	DLL 8/22/89		TYPE "C" W/O PROTECTOR
APPR.	DJW 8/22/89	MAT'L.	42 - FRAME
SCALE	1=1		DECAL - 004012
REF.	005005-19	FINISH	STANDARD
FMF		SIZE	A
		DRAWING NO.	005312-01