

Installation and Service Instructions for Self Adjust Brakes 82,000 Series (rev. A)

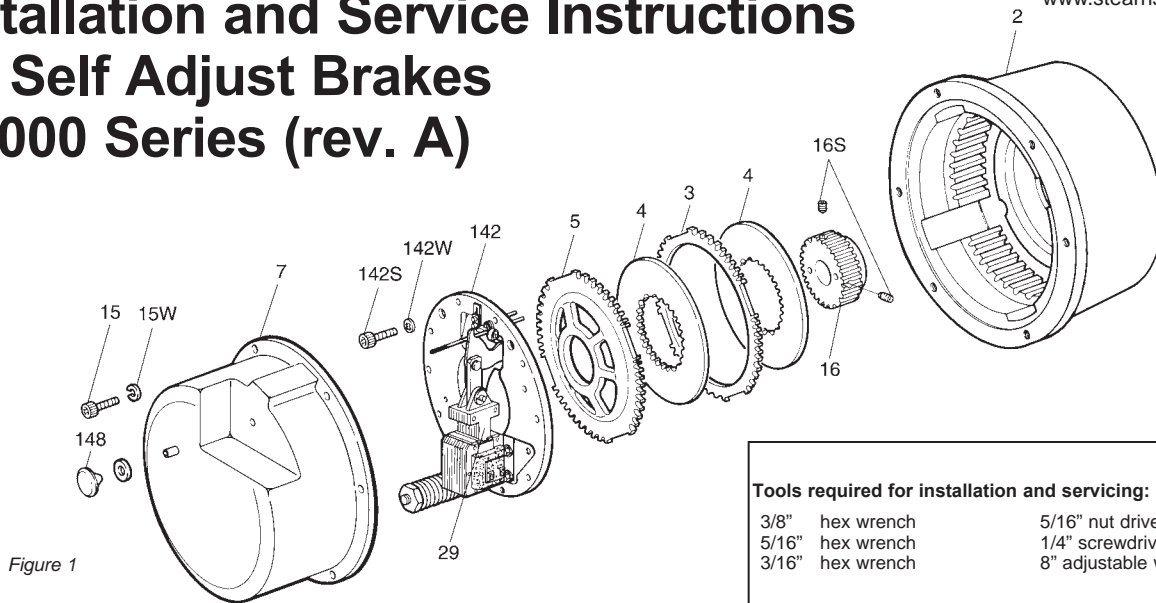
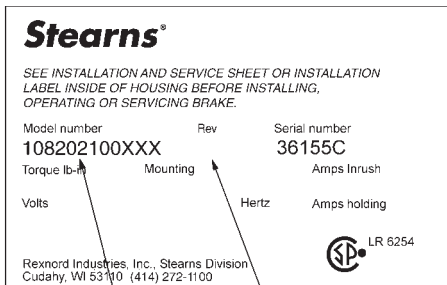

Figure 1

Tools required for installation and servicing:

3/8" hex wrench	5/16" nut driver
5/16" hex wrench	1/4" screwdriver
3/16" hex wrench	8" adjustable wrench



Note:

MODEL NUMBER
Refer to actual nameplate on brake for additional information

REVISION CONTROL

Important

Please read these instructions carefully before installing, operating, or servicing your Stearns Brake. Failure to comply with these instructions could cause injury to personnel and/or damage to property if the brake is installed or operated incorrectly. For definition of limited warranty/liability, contact Rexnord Industries, LLC, Stearns Division, 5150 South International Dr., Cudahy, WI 53110, (414) 272-1100.

Caution

1. Installation and servicing must be made in compliance with all local safety codes including Occupational Safety and Health Act (OSHA). All wiring and electrical connections must comply with the National Electric Code (NEC) and local electric codes in effect.
2. Use of this brake in atmospheres containing explosive gases and dusts must be in accordance with NEC article 501. This brake is not suitable for use in certain atmospheres containing explosive gases and dusts. **HazLoc** inspection authorities are responsible for verifying and authorizing the use of suitably designed and installed **HazLoc** equipment. When questions arise consult local **Authority Having Jurisdiction (AHJ)**.

3. To prevent an electrical hazard, disconnect power source before working on the brake. If power disconnect point is out of sight, lock disconnect in the off position and tag to prevent accidental application of power.
4. Make certain power source conforms to the requirements specified on the brake nameplate.
5. Be careful when touching the exterior of an operating brake. Allow sufficient time for brake to cool before disassembly. Surfaces may be hot enough to be painful or cause injury.
6. Do not operate brake with housing removed. All moving parts should be guarded.
7. Installation and servicing should be performed only by qualified personnel familiar with the construction and operation of the brake.
8. For proper performance and operation, only genuine Stearns parts should be used for repairs and replacements.
9. After usage, the brake interior will contain burnt and degraded friction material dust. This dust must be removed before servicing or adjusting the brake.

DO NOT BLOW OFF DUST using an air hose. It is important to avoid dispersing dust into the air or inhaling it, as this may be dangerous to your health.

- a) Wear a filtered mask or a respirator while removing dust from the inside of a brake.
- b) Use a vacuum cleaner or a soft brush to remove dust from the brake. When brushing, avoid causing the dust to become airborne. Collect the dust in a container, such as a bag, which can be sealed off.

10. **Caution!** While the brake is equipped with a manual release to allow manual shaft

rotation, the motor should not be run with the manual release engaged, to avoid overheating the friction disc(s).

General Description

This series of brake is spring-set, electrically released. They contain two to five rotating friction discs (4) driven by a hub (16) mounted on the motor or other shaft.

Note: Fan-guard mounted brakes requiring IP54 & IP55 protection may require additional sealing measures beyond seals provided with this brake. Pressurized sprays aimed at the fan and brake hub surfaces can result in fluid migration along the motor shaft and keyway, and into the brake. The use of an appropriate sealant such as *RTV* or a *forsheda* seal is advised.

Operating Principle

This series contains two or more friction discs (4) assembled alternately between the endplate (2) friction surface, stationary disc(s) (3) and pressure plate (5). The stationary components are restrained from rotating by being keyed into the endplate. With the brake released, all disc pack components are free to slide axially and the friction disc(s) to rotate.

Brake release occurs when the solenoid coil is electrically energized, causing the solenoid plunger to travel a specified distance and through a lever system, overcoming the pressure spring force. This action releases the clamping force on the disc pack, thereby allowing the friction disc(s) and brake hub to rotate.

Brake sets and torque is produced when electric current to the solenoid coil is interrupted, thereby collapsing the solenoid magnetic field. The solenoid plunger returns to its original de-energized position allowing the lever arm to move forward by virtue of the compressed torque springs. This action compresses the disc pack components which applies a retarding torque to the brake hub and ultimately restores the brake to a spring-set static condition.

- 1** Remove manual release knob.
Remove housing screws.
Remove housing.

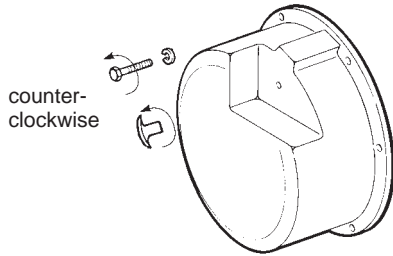

- 2** A. Push plunger down.
B. Pull manual release to hold plunger.
C. Remove support plate screws.

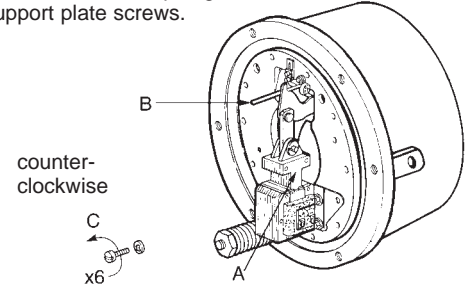

- 3** Lift off support plate.
Remove disc pack.

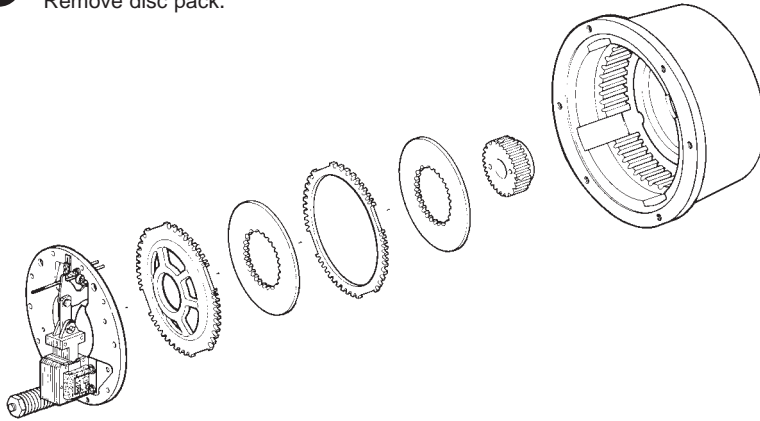

- 4** A. Position endplate on motor register.
B. Insert four mounting bolts and tighten.
(Torque per manufacturer specification)

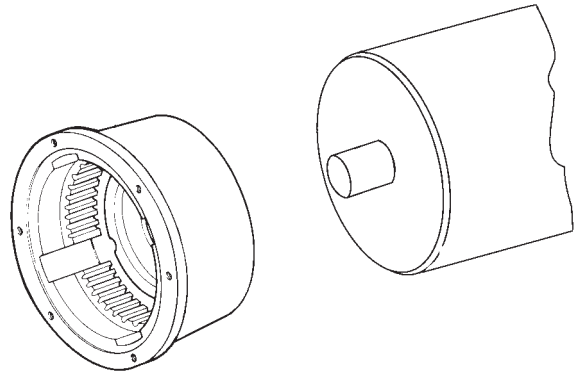

- 5** A. Position hub on shaft so that the inner surface is flush with motor register.
Torque to: 5/16" - 156 lb-in;
3/8" - 288 lb-in;
1/2" - 625 lb-in.
B. Reassemble disc pack in reverse order of removal.*

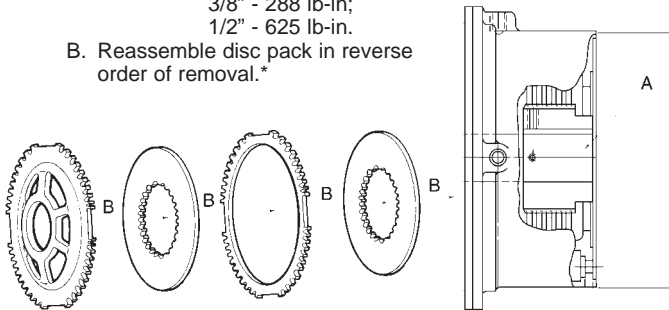

* For vertical bakes refer to Service Instruction Sheet 8-078-932-06.

- 6** A. Route lead wires through conduit hole.
B. Position support plate on endplate.
C. Insert six mounting screws with lockwashers; tighten to 85-100 lb-in.

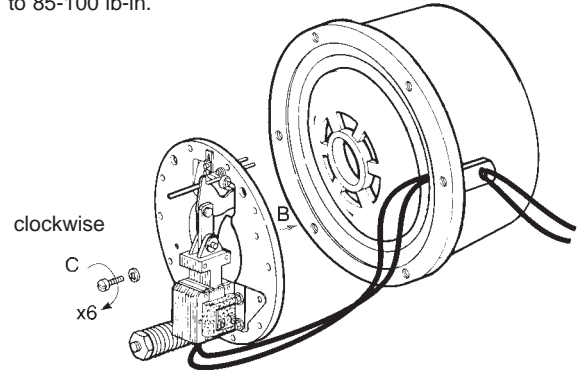

- 7** AC coils are 50/60 hz, single phase rated. Power supply to coil must not have current or frequency limiting output that is less than the coil requirement. Voltage supply to the coil must be within $\pm 10\%$ of nameplate rating.*

Caution: Keep wiring away from pinch points.

* For DC voltages see sheet 8-078-950-00.

Coil Wiring

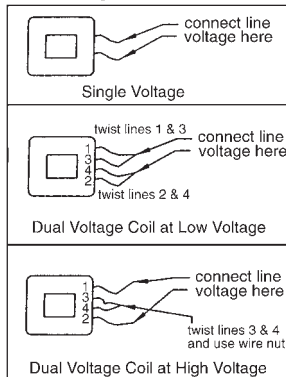

- 8** Replace housing.
Tighten housing screws to 130 lb-in and release knob to 50 in-lb.

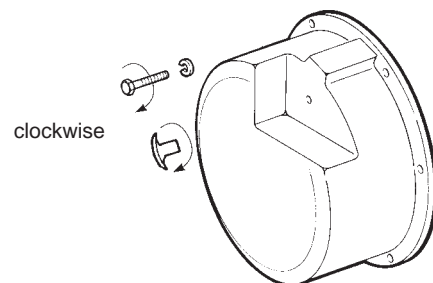

General Maintenance

Warning! Any mechanism or load held in position by the brake should be secured to prevent possible injury or damage to equipment before any disassembly of the brake is attempted or the manual release knob or lever is operated on the brake. Observe all cautions listed at the beginning of this manual.

Note: Do not lubricate any part of the brake as this may cause a malfunction and/or a loss of torque.

Troubleshooting

A. If brake does not stop properly, coasts or overheats:

1. Check that manual release knob is not in released mode.
2. Check for excessively worn, charred or broken friction discs.
3. Check that hub has not loosened and shifted on motor shaft.
4. Check that friction discs slide freely over hub. Clean hub and /or file burrs and nicks if required.
5. Check that stationary disc(s) and/or pressure plate can move freely in endplate and that they are not warped from overheating.
6. Check endplate slots for wear in the areas where stationary disc(s) and/or pressure plate make contact. Grooves in slots can prevent free disc movement and result in torque loss, stationary disc or friction disc breakage.
7. On vertically mounted brakes, check that springs are installed correctly. Check for wear on plunger guide bracket.
8. Confirm that the pressure spring nut (19) is properly tightened against the spacer (134) under the nut. Spring length should be measured from the cast surface of the support plate to the bottom side of the spring nut. Spring lengths are based on the brake fully assembled, using a new disc pack. Spring length will increase as the disc pack wears.
9. Check solenoid air gap (see page 4). Adjust if necessary.
10. Check that solenoid linkage can move freely. It requires approximately 18 lbs of pressure on the 125 lb-ft; 23 lbs on the 175, and 230 lb-ft; 28 lbs on 330, 440 and 550 lb-ft to seat solenoid plunger correctly functioning brake.
11. Check voltage reading at coil terminals against coil voltage rating.

Torque (lb-ft)	Compressed Spring Length
125	4-23/32
175	4-23/32
230	4-27/32
330	5-3/32
440	5-3/32
550	5-3/32

12. Check that brake coil is energized at the same time as, or prior to, motor and de-energized at the same time, or after, motor.
13. If stopping time exceeds 1 second, or if the application requires more than five stops per minute, check the thermal requirements to stop load against the thermal capacity of the brake.
14. Check for excessive voltage drop in motor line when motor is started. Check wire gauge of supply line against motor starting current and solenoid inrush current. Measure voltage drop at solenoid coil terminals during maximum inrush current condition. To accomplish this, insert a block of wood, or other non-magnetic material, between solenoid plunger and frame. Block thickness should approximately equal solenoid air gap. Energize motor and brake simultaneously, take reading and immediately shut down. This is to prevent motor, brake, or solenoid burnup.

B. If brake hums, solenoid pulls in slowly, or coil burns out:

1. Check Items A-7, A-9, A-11 and A-14.
2. Check if shading coils are broken.
3. Check for worn plunger guides or if plunger rubs on solenoid frame laminations.
4. Check for worn solenoid plunger and frame.
5. Check if solenoid is dirty.
6. Check if solenoid mounting screws have loosened.
7. Check for worn or binding linkage. For normal pressure required to seat solenoid plunger to frame see A-10.

C. If brake is noisy during stopping and/or friction discs shatter:

1. Check for worn motor bearings allowing shaft runout.
2. On foot mounted brakes, recheck alignment.
3. Check hub position on shaft. The outboard face of hub should protrude 3/32" to 1/8" beyond face of outboard friction disc.
4. Check motor shaft endfloat. It should not exceed 0.020".
5. Check concentricity of endplate and C-face register. Alignment must be within .007" concentricity and face runout. Shaft runout should be within .002" TIR.

Vertical Brake Assembly

Refer to service sheet 8-078-932-05 for proper spring and spacer positions when brake is assembled for vertical orientation.

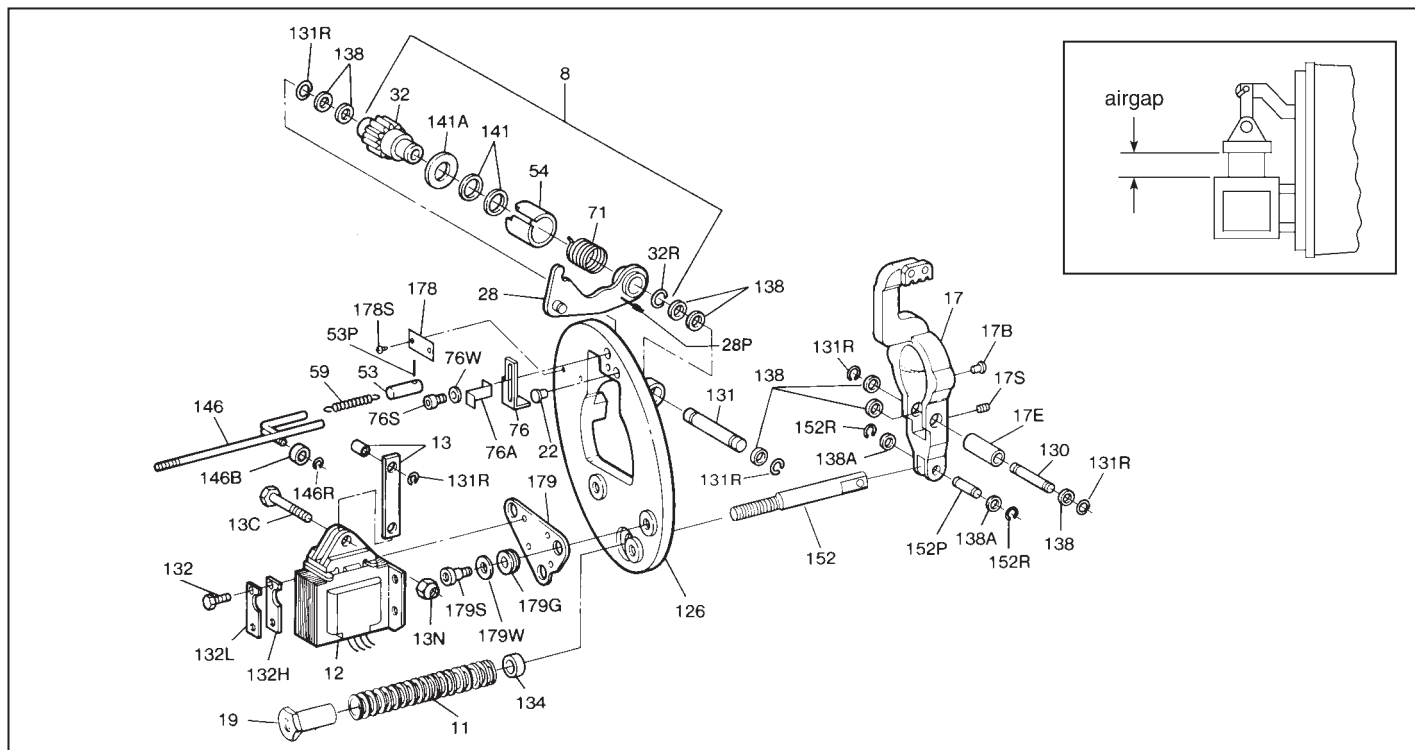

- 1** **Note:** Refer to page 2, Brake Mounting, for removal and replacement of housing. Loosen two locking screws. Slide bracket outward to increase or inward to decrease air gap. Tighten screws to 75-78 lb-in.

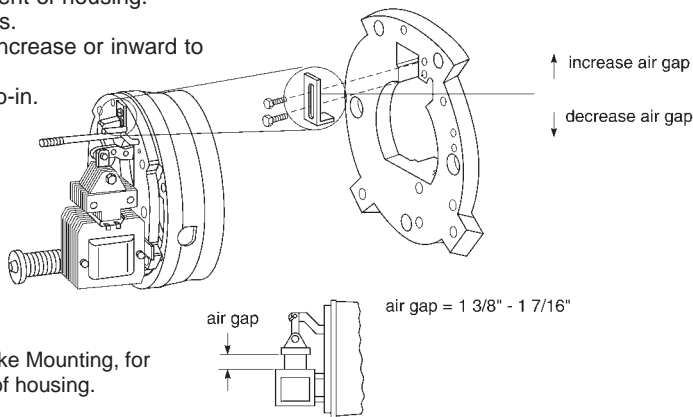

Note: Refer to page 2, Brake Mounting, for removal and replacement of housing.

Wrap spring stop ① is positioned above the tang of the wrap spring ②

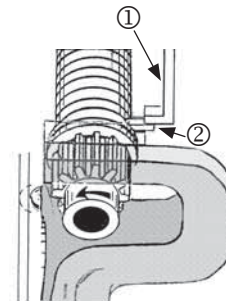

COIL REPLACEMENT

- 1** Disconnect coil lead wires from power source and pull them out of the brake.

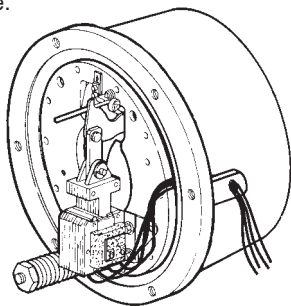

Note: Refer to page 2, Brake Mounting, for removal and replacement of housing.

- 2** A. Remove solenoid mounting screws. B. Lift solenoid frame away from plunger.

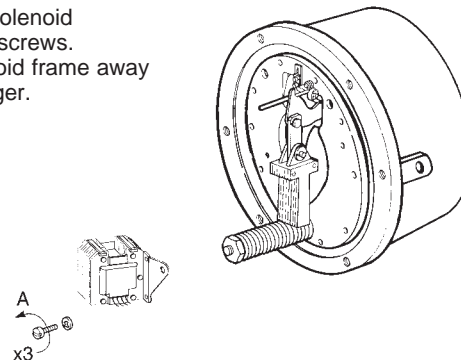

- 3** A. Remove guide screws. B. Lift guides out of coil. C. Push coil out of frame.

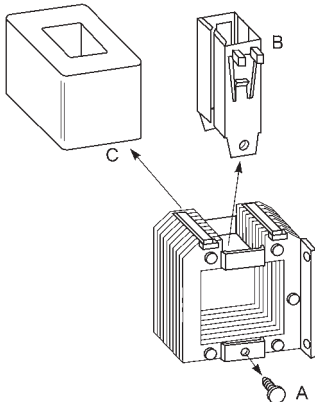

- 4** A. Insert new coil. B. Press plunger guides into place. C. Insert and tighten guide screws.

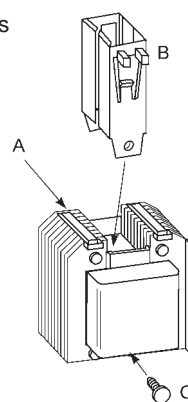

- 5** A. Slide coil assembly on to plunger. B. Insert mounting screws and tighten to 125 lb-in.

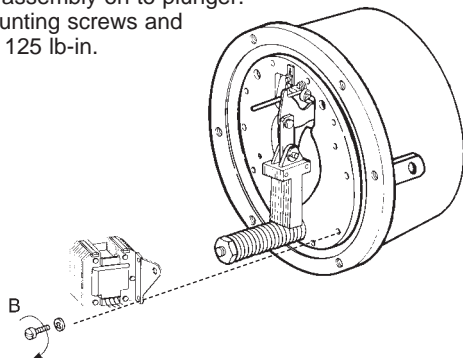

- 6** Reroute coil wires and reconnect to power supply.

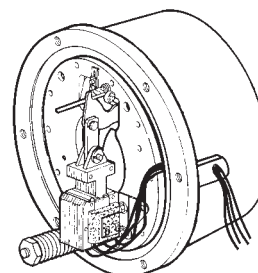

FRICION DISC REPLACEMENT

[BACK TO PRODUCT PAGE](#)

- 1** **Note:** Refer to page 2, Brake Mounting, for removal and ressembly of housing.
- A. Push plunger down.
 - B. Pull manual release to hold plunger.
 - C. Remove support plate screws.

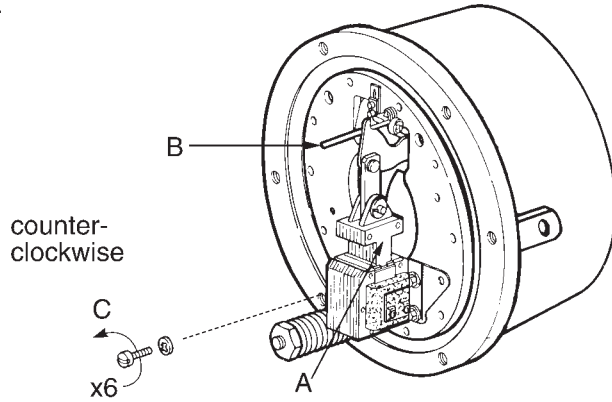

Friction Disc Wear:

- 1. Discs can wear to 50% of original thickness, or .187".
- 2. Entire wear of disc pack cannot exceed the thickness of a new disc, or .375".

- 2**
- A. Remove support plate.
 - B. Remove disc pack components.
 - C. Discard old friction discs.

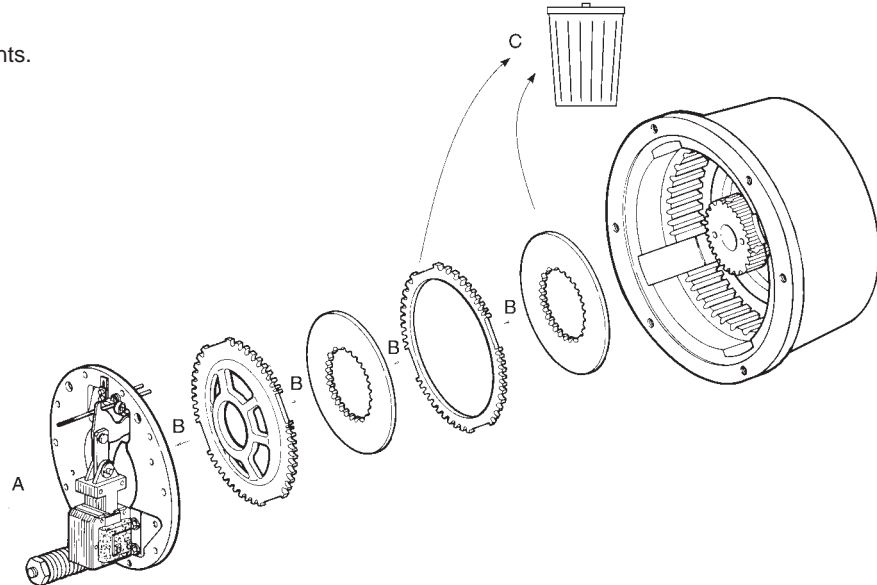

- 3**
- A. Install new friction discs and reassemble in reverse order of disassembly.*
 - B. Position support plate and tighten six screws to 75-78 lb-in.

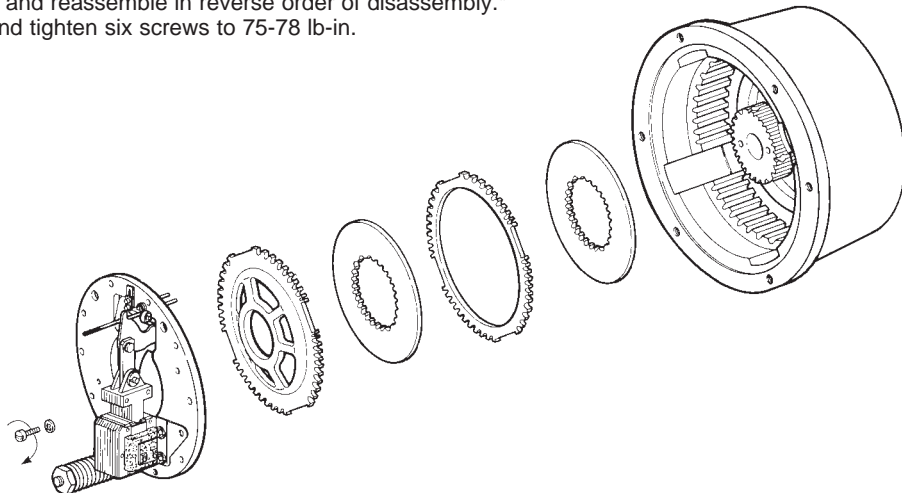

* For vertical brakes refer to Service Instruction Sheet 8-078-932-06.

Information required when ordering replacement parts:

- Give part number of parts needed, brake model number and brake serial number. The brake model and serial number may identify special brakes not covered by this parts list.
- When ordering hubs, specify shaft diameter (hub bore) and keyway.
- Consult factory regarding support plate assembly for vertical and extra items.
- Enclosures are designated as follows: **O** = Standard
E = Dust-tight, waterproof (DTWP)

General Information

- For vertical details, see P/N 8-078-932-06 and SA-701.

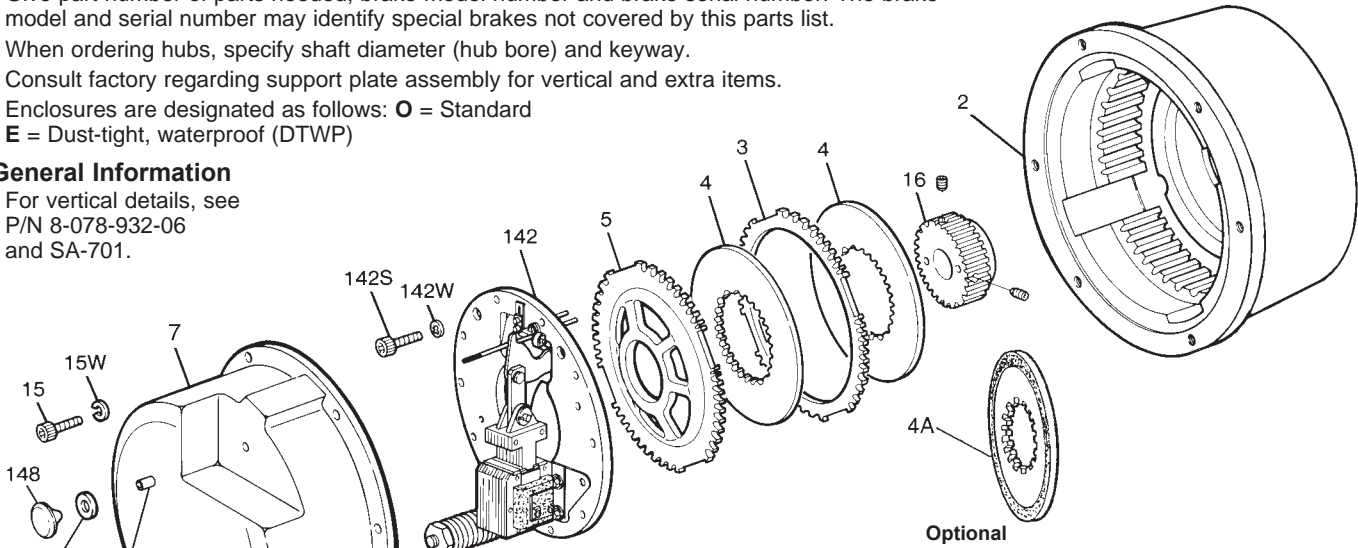

TABLE 1
Components of Standard Horizontal AC or DC Units

Torque (lb-ft)	125		175		230		330		440		550	
	AC	DC	AC	DC	AC	DC	AC	DC	AC	DC	AC	DC
Enclosure	O	E	O	E	O	E	O	E	O	E	O	E
Brake Model Number→	Part Number↓											
2	1	1	1	1	1	1	1	1	1	1	1	1
2S	1	1	1	1	1	1	1	1	1	1	1	1
3	1	1	1	1	1	1	1	1	1	1	1	1
4	2	2	2	2	2	2	2	2	2	2	2	2
4A												
5	1	1	1	1	1	1	1	1	1	1	1	1
7	1	1	1	1	1	1	1	1	1	1	1	1
optional 7B	1	1	1	1	1	1	1	1	1	1	1	1
7D	1	1	1	1	1	1	1	1	1	1	1	1
7S	1	1	1	1	1	1	1	1	1	1	1	1
15	6	6	6	6	6	6	6	6	6	6	6	6
15W	6	6	6	6	6	6	6	6	6	6	6	6
16	1	1	1	1	1	1	1	1	1	1	1	1
69	1	1	1	1	1	1	1	1	1	1	1	1
140	1	1	1	1	1	1	1	1	1	1	1	1
142	1	1	1	1	1	1	1	1	1	1	1	1
142S	6	6	6	6	6	6	6	6	6	6	6	6
142W	6	6	6	6	6	6	6	6	6	6	6	6
148	1	1	1	1	1	1	1	1	1	1	1	1

x = -02 (cast iron housing)
 -03 (cast aluminum housing)

TABLE 2
 Components for Standard Modifications

Type of Modification	Item No.	Description (most items not shown)	Part Number↓	Torque (lb-ft)																							
				125				175				230				330				440				550			
				Current		DC		AC		DC		AC		DC		AC		DC		AC		DC		AC		DC	
				O	E	O	E	O	E	O	E	O	E	O	E	O	E	O	E	O	E	O	E	O	E	O	E
Brake Model Number→				1-082-011-0X	1-082-012-0X	1-082-015-0X	1-082-016-0X	1-082-021-0X	1-082-022-0X	1-082-025-0X	1-082-026-0X	1-082-031-0X	1-082-032-0X	1-082-035-0X	1-082-036-0X	1-082-041-0X	1-082-042-0X	1-082-045-0X	1-082-046-0X	1-082-051-0X	1-082-052-0X	1-082-055-0X	1-082-056-0X				
Vertical Mounting Above Motor	2	See Table 1 for endplate																									
	3	Stationary disc	8-003-206-02	1	1	1	1	1	1	1	1	2	2	2	2	2	2	2	3	3	3	3					
	5	Pressure plate	8-005-205-02									1	1	1	1	1	1	1									
		Pressure plate	8-005-206-02	1	1	1	1	1	1	1	1								1	1	1	1	1	1			
	7	Housing and side release assembly	5-07-1002-00		1		1		1		1				1												
	Not Shown	Vertical spring kit	5-96-0205-00	1	1	1	1	1	1	1	1	1	1	1	1	1	1	1	1	1	1	1	1	1			
Vertical Mounting Below Motor	170	Plunger guide bracket	<i>kit</i> 5-55-2002-00	1	1	1	1	1	1	1	1	1	1	1	1	1	1	1	1	1	1	1	1				
	170S	Cap screw (bracket)																									
	170W	Lock washer (bracket)																									
	171	Shim (bracket)																									
	172	Spacer																									
Vertical Mounting Below Motor		Release plate	8-170-102-00		1		1		1		1		1		1		1		1		1		1				
		Screw	9-16-3012-00		2		2		2		2		2		2		2		2		2		2				
		Lock nut	9-40-3730-00		2		2		2		2		2		2		2		2		2		2				
		Spring pin	9-32-4055-00		1		1		1		1		1		1		1		1		1		1				
		Release rod	8-146-201-01		1		1		1		1		1		1		1		1		1		1				
Vertical Mounting Below Motor	34	Foot mounting kit, comprised of:	5-55-2022-00	1	1	1	1	1	1	1	1	1	1	1	1	1	1	1	1	1	1	1	1				
	34S	Foot mounting bracket	8-034-205-01	4	4	4	4	4	4	4	4	4	4	4	4	4	4	4	4	4	4	4	4				
		Cap screw	9-17-1624-00	4	4	4	4	4	4	4	4	4	4	4	4	4	4	4	4	4	4	4	4				
	39W	Lock washer	9-45-0336-00	4	4	4	4	4	4	4	4	4	4	4	4	4	4	4	4	4	4	4	4				
Vertical Mounting Below Motor	3	Stationary disc	8-003-206-02	1	1	1	1	1	1	1	2	2	2	2	2	2	2	2	3	3	3	3					
	5	Pressure plate	8-005-205-02								1	1	1	1	1	1	1	1									
		Pressure plate	8-005-206-02	1	1	1	1	1	1	1									1	1	1	1	1				
	Not Shown	Vertical spring kit	5-96-0206-00	1	1	1	1	1	1	1	1	1	1	1	1	1	1	1	1	1	1	1	1				
Shaft Through Housing	7	Housing, bearing and seal assembly	5-07-2014-00		1		1		1		1		1		1		1		1		1		1				
	24	Shaft bushing (specify bore)	8-024-202-01		1		1		1		1		1		1		1		1		1		1				
	24L	Set screw (shaft bushing)	9-20-3004-00		2		2		2		2		2		2		2		2		2		2				
	24S	Shaft seal (component of Item 7)	9-02-0010-00		1		1		1		1		1		1		1		1		1		1				
Brass Parts (horizontal & vertical brake)	3	Stationary disc	8-003-208-02	1	1	1	1	1	1	1	2	2	2	2	2	2	2	2	3	3	3	3					
	4	Friction disc	5-66-8424-00	2	2	2	2	2	2	2	3	3	3	3	3	3	3	3	4	4	4	4					
	5	Pressure plate	8-005-207-01								1	1	1	1	1	1	1	1									
Space Heater Kit	Not shown	Heater (115 volt circuit)	5-27-2006-00	1	1	1	1	1	1	1	1	1	1	1	1	1	1	1	1	1	1	1	1				
		Heater (230 volt circuit)	5-27-2007-00	1	1	1	1	1	1	1	1	1	1	1	1	1	1	1	1	1	1	1	1				

550 lb-ft brake is not available for vertical operation

*as required

Table 3 (see Note)
Components of Support Plate Assemblies

Item No.	Description	Part Number↓	Brake Size (lb-ft)							
			125		175		230		330	
			440	550	440	550	440	550	440	550
			Current		Current		Current		Current	
			AC	DC	AC	DC	AC	DC	AC	DC
			Assembly Part Number→							
			5-42-2071-00-09	5-42-2072-00-09	5-42-2073-00-09	5-42-2074-00-09	5-42-2075-00-09	5-42-2076-00-09	5-42-2077-00-42	5-42-2078-00-09
8	Solenoid lever and pinion assembly (comprised of Items 28, 32, 32R, 54, 71, 141 and 141A)	5-66-7321-00	1	1	1	1	1	1	1	1
11	Pressure spring (green) Pressure spring (yellow) Pressure spring (red)	9-70-4601-00 9-70-6001-00 9-70-5801-00	1	1	1	1	1	1	1	1
13 13C 13N	Solenoid link and bearing assembly Cap screw (solenoid link) Nut (solenoid link)	5-55-2006-00 8-157-703-00 9-40-3732-00	1	1	1	1	1	1	1	1
17 17B 17E 17S	Lever arm assembly Pressure button Eccentric sleeve (lever arm) Set screw (lever arm)	5-17-2001-00 9-25-1908-00 8-054-201-00 9-20-3004-00	1	1	1	1	1	1	1	1
19 22	Pressure spring nut Solenoid lever stop	8-019-202-01 8-022-603-00	1	1	1	1	1	1	1	1
53 53P 59	Manual release spring tube Roll pin (spring tube) Release spring	8-053-201-00 9-32-4012-00 9-71-0004-00	1	1	1	1	1	1	1	1
76 76A 76S 76W	Wrap spring stop Holding plate (wrap spring stop) Cap screw (spring stop) Lock washer (spring stop)	8-076-203-00 8-076-204-00 9-17-2812-00 9-45-1328-00	1	1	1	1	1	1	1	1
126 130 131 131R	Support plate and bearing assembly Pivot pin (lever arm) Pivot pin (solenoid lever) Retaining ring (pivot pin)	5-26-2004-00 8-118-204-00 8-131-201-00 9-03-0020-00	1	1	1	1	1	1	1	1

Table 3 (see Note)
Components of Support Plate Assemblies

Item No.	Description	Part Number↓	Brake Size (lb-ft)							
			125		175		230		330	
			440	550	440	550	440	550	440	550
			Current		Current		Current		Current	
			AC	DC	AC	DC	AC	DC	AC	DC
			Assembly Part Number→							
			5-42-2071-00-09	5-42-2072-00-09	5-42-2073-00-09	5-42-2074-00-09	5-42-2075-00-09	5-42-2076-00-09	5-42-2077-00-42	5-42-2078-00-09
132	Cap screw (solenoid mounting)	8-350-008-00	4	4	4	4	4	4	4	4
132H	Holding plate (solenoid mounting)	8-076-207-00	2	2	2	2	2	2	2	2
132L	Lock plate (solenoid mounting)	8-076-206-00	2	2	2	2	2	2	2	2
134	Pressure spring spacer Pressure spring spacer Pressure spring spacer	8-134-001-02 8-134-001-03 8-134-001-05	1	1	1	1	1	1	1	1
138 138A	Bearing (washer type) Bearing (washer type)	8-138-201-00 8-138-701-00	8	8	8	8	8	8	8	8
146 146B 146R	Release rod Ball bearing (release rod) Retaining ring (release rod)	8-146-201-00 9-01-6801-00 9-03-0007-00	1	1	1	1	1	1	1	1
152 152P 152R	Pressure spring stud Pivot pin (spring stud) Retaining ring (spring stud)	8-152-201-00 8-118-202-00 9-03-0019-00	1	1	1	1	1	1	1	1
159	Brake release interlock kit (standard manual release) Brake release interlock kit (side manual release)	5-55-2005-00 5-55-2004-00	1	1	1	1	1	1	1	1
178 178S 179 179G 179S 179W	Instruction plate Drivescrew Solenoid mounting plate Grommet (mounting plate) Shoulder screw (mounting plate) Washer (mounting plate)	8-078-055-00 9-25-1303-00 8-179-205-01 8-147-202-00 9-26-1108-00 8-138-202-00	1	1	1	1	1	1	1	1

Note: Some brakes manufactured prior to the "-02" series had solenoid which were mounted on (4) rubber shock mounts. Conversion kits are available to replace these mounts. Kit 5-12-9595 replaces 1" diameter by 17/32" high mounts with 1/4-20 studs. Kit 5-12-9594 replaces 1-1/4" diameter by 3/4" high mounts with 5/16-18 studs. Kit 5-12-9593 must replace mounts on serial numbers B-960232 through 69 and B-989748.

Table 4
Components of Solenoid and Coil Assemblies

Item	Description	Part Number	Torque (lb-ft)	
			125	330
AC Brakes			175	440
			230	550
12	Solenoid assembly (AC)	5-12-5529-00	1	1
12A	No. 9 coil assembly 60 Hz	115 Vac	5-96-6901-33	1
		230 Vac	5-96-6902-33	1
		460 Vac	5-96-6904-33	1
		575 Vac	5-96-6905-33	1
		115/230 Vac	5-96-6907-33	1
		230/460 Vac	5-96-6909-33	1
	No. K9 coil assembly 60 Hz	115 Vac	5-96-6951-33	1
		230 Vac	5-96-6952-33	1
		460 Vac	5-96-6954-33	1
		575 Vac	5-96-6955-33	1
		115/230 Vac	5-96-6957-33	1
		230/460 Vac	5-96-6959-33	1

Solenoid and Coil Assembly

Table 5
Contents of Assemblies and Kits

Item No.	Description
12	Solenoid assembly (5-12-55XX-00) 1 - Plunger 1 - Frame 2 - Lock plates 1 - Solenoid link cap screw 1 - Solenoid link nut 1 - Cable clamp and screw (DC only)
12A	Coil assembly (5-96-69XX-33) 1 - Coil 2 - Plunger guides 2 - Plunger guide screws
159	Brake switch kit (5-55-2004-00 or 5-55-2005-00) (brake release interlock switch - N.O.) 1 - Microswitch 1 - Bracket, microswitch 1 - Bracket, mounting 1 - Mounting hardware

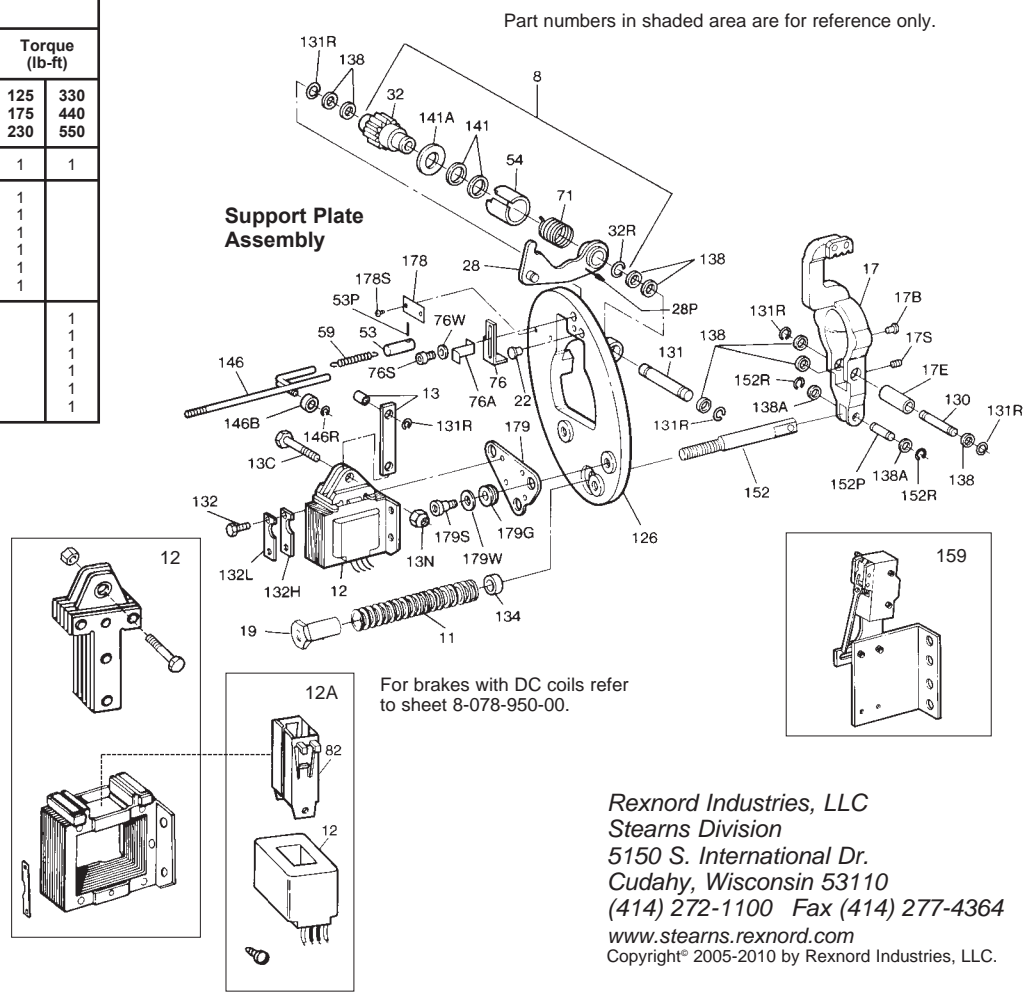

Rexnord Industries, LLC
Stearns Division
5150 S. International Dr.
Cudahy, Wisconsin 53110
(414) 272-1100 Fax (414) 277-4364
www.stearns.rexnord.com
Copyright© 2005-2010 by Rexnord Industries, LLC.